

Item Number: 1.5THF-C (includes base, sleeve, & cover)

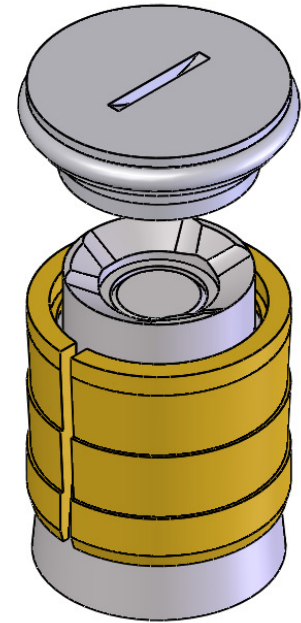

S ϕ 1.5000
REFERENCE BALL

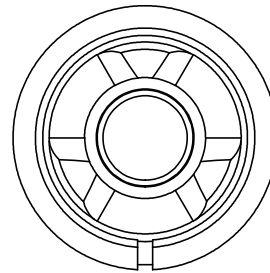
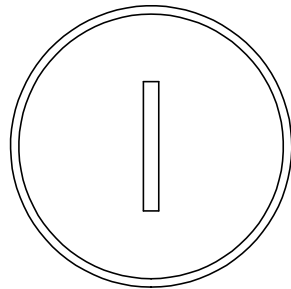
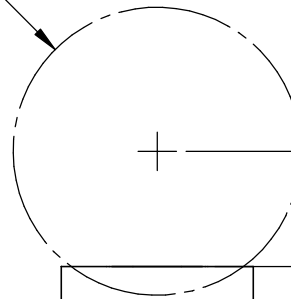

(.60
[15.3])

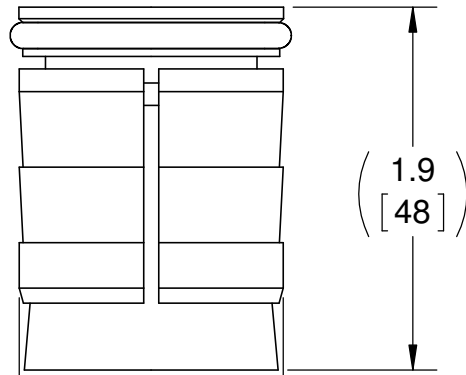

(1.9
[48])

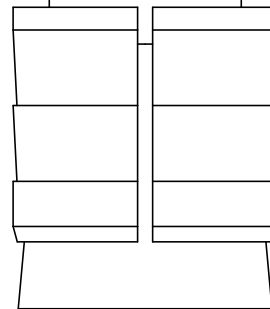

(ϕ 1.37
[34.9])

DIMENSIONS:

INCH X.XX
MM [X.XX]
REFERENCE (X.XX)



Brunson Instrument Company
8000 E. 23rd Street
Kansas City, MO 64129

Tel: 800-445-9405
Fax: 816-241-1945
Email: Sales@Brunson.us

TITLE: 1.5THF-C COMPRESSION FLOOR MOUNT ADAPTER

MATERIAL: STAINLESS STEEL W/ BRASS SLEEVE

HARDNESS: HRC 42-45 (STAINLESS STEEL ONLY)

FINISH: MACHINED

WEIGHT (ESTIMATED)

0.77 LBS

SIZE

A

DATE: 1/13/2014

SCALE: 1:1

PROPRIETARY AND CONFIDENTIAL
THE INFORMATION CONTAINED IN THIS DRAWING IS THE SOLE PROPERTY OF BRUNSON INSTRUMENT COMPANY. ANY REPRODUCTION IN PART OR AS A WHOLE WITHOUT THE WRITTEN PERMISSION OF BRUNSON INSTRUMENT COMPANY IS PROHIBITED.