

Item Number Format: 0.5SC

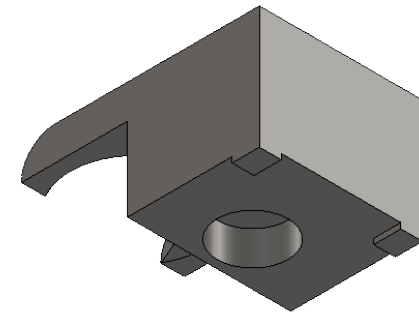
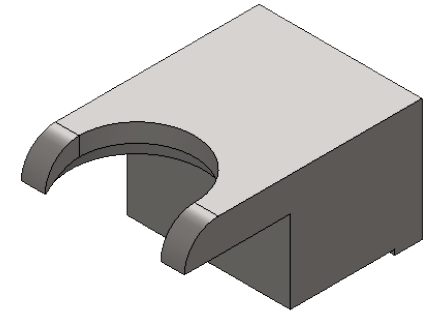
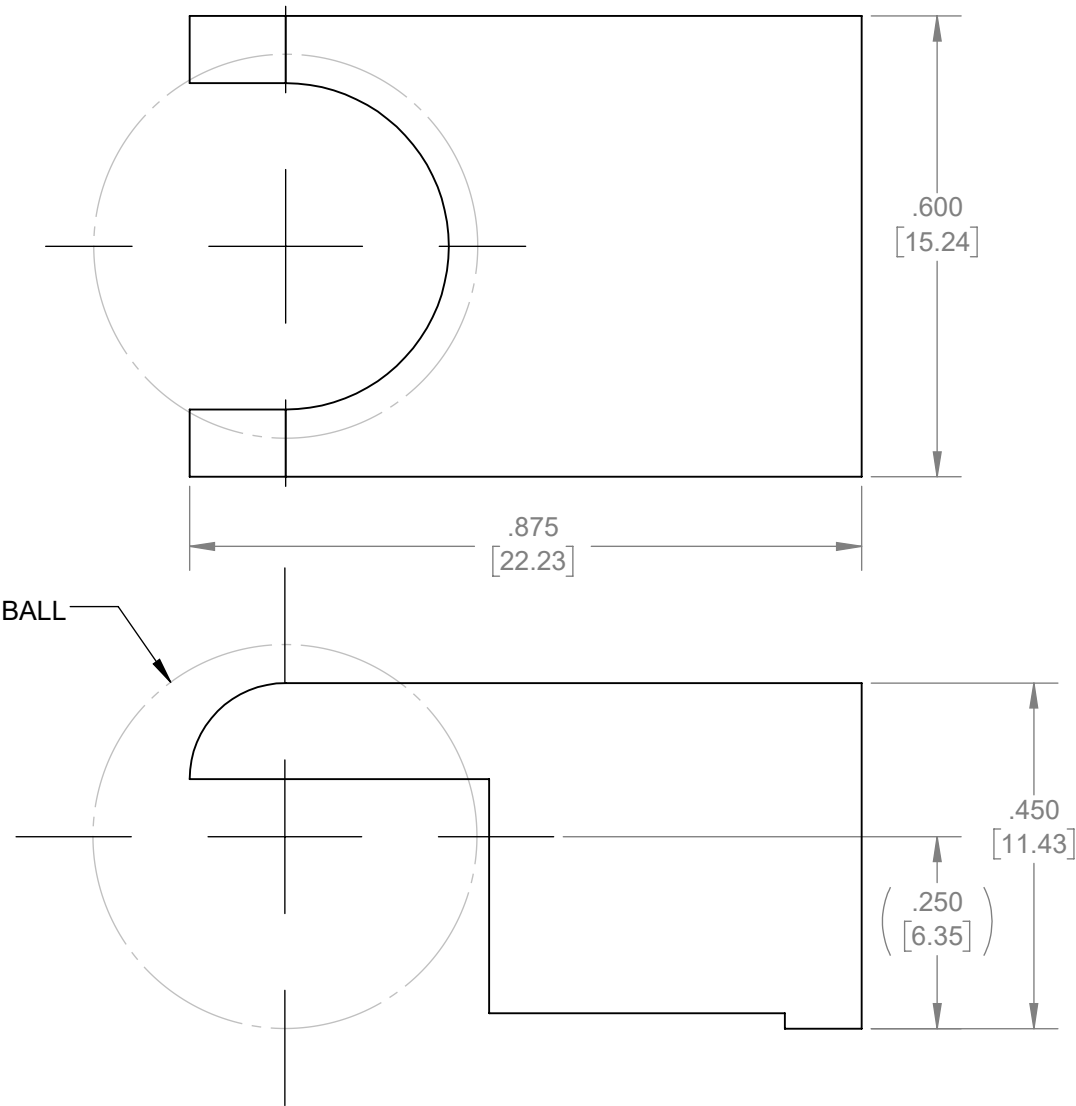

DIMENSIONS:

INCH X.XX
MM [X.XX]
REFERENCE (X.XX)

PROPRIETARY AND CONFIDENTIAL
THE INFORMATION CONTAINED IN THIS DRAWING IS THE SOLE PROPERTY OF BRUNSON INSTRUMENT COMPANY. ANY REPRODUCTION IN PART OR AS A WHOLE WITHOUT THE WRITTEN PERMISSION OF BRUNSON INSTRUMENT COMPANY IS PROHIBITED.



Brunson Instrument Company
8000 E. 23rd Street
Kansas City, MO 64129

Tel: 800-445-9405
Fax: 816-241-1945
Email: Sales@Brunson.us

TITLE: 0.5SC SURFACE CLAMP - 0.5" TARGET BODY

MATERIAL: 17-4 SS

HARDNESS: N/A

FINISH: MACHINED

WEIGHT (ESTIMATED)

0.038 LBS

SIZE

A

DATE: 2/7/2017

SCALE: 2:1